

PRODUCT INFORMATION PACKET

Model No: A099901.00

Catalog No: A099901.00

0.50 HP Agricultural Motor, 1 phase, 1800 RPM, 115/230 V, 48Z Frame, TEAO



Regal and are trademarks of Regal Rexnord Corporation or one of its affiliated companies.
©2022 Regal Rexnord Corporation, All Rights Reserved. MC017097E

Nameplate Specifications

Output HP	0.50 Hp	Output KW	0.37 kW
Frequency	60 Hz	Voltage	115/230 V
Current	5.2/2.6 A	Speed	1625 rpm
Service Factor	1	Phase	1
Efficiency	72 %	Power Factor	98
Duty	Continuous	Insulation Class	F
Design Code	N	KVA Code	B
Frame	48Z	Enclosure	Totally Enclosed Air Over
Thermal Protection	Automatic	Ambient Temperature	40 °C
Drive End Bearing Size	6203	Opp Drive End Bearing Size	6203
UL	Recognized	CSA	Y
CE	N	IP Code	43
Number of Speeds	1		

Technical Specifications

Electrical Type	Permanent Split Capacitor	Starting Method	Across The Line
Poles	4	Rotation	Selective Counterclockwise
Resistance Main	0 Ohms	Mounting	Rigid - Extended Studs
Motor Orientation	Horizontal	Drive End Bearing	Ball
Opp Drive End Bearing	Ball	Frame Material	Rolled Steel
Shaft Type	Single Special Extension	Overall Length	10.89 in
Frame Length	5.50 in	Shaft Diameter	0.500 in
Shaft Extension	2.24 in	Assembly/Box Mounting	F1 ONLY
Outline Drawing	SS404060-550	Connection Drawing	005109-15

This is an uncontrolled document once printed or downloaded and is subject to change without notice. Date Created:06/08/2022

SS404060

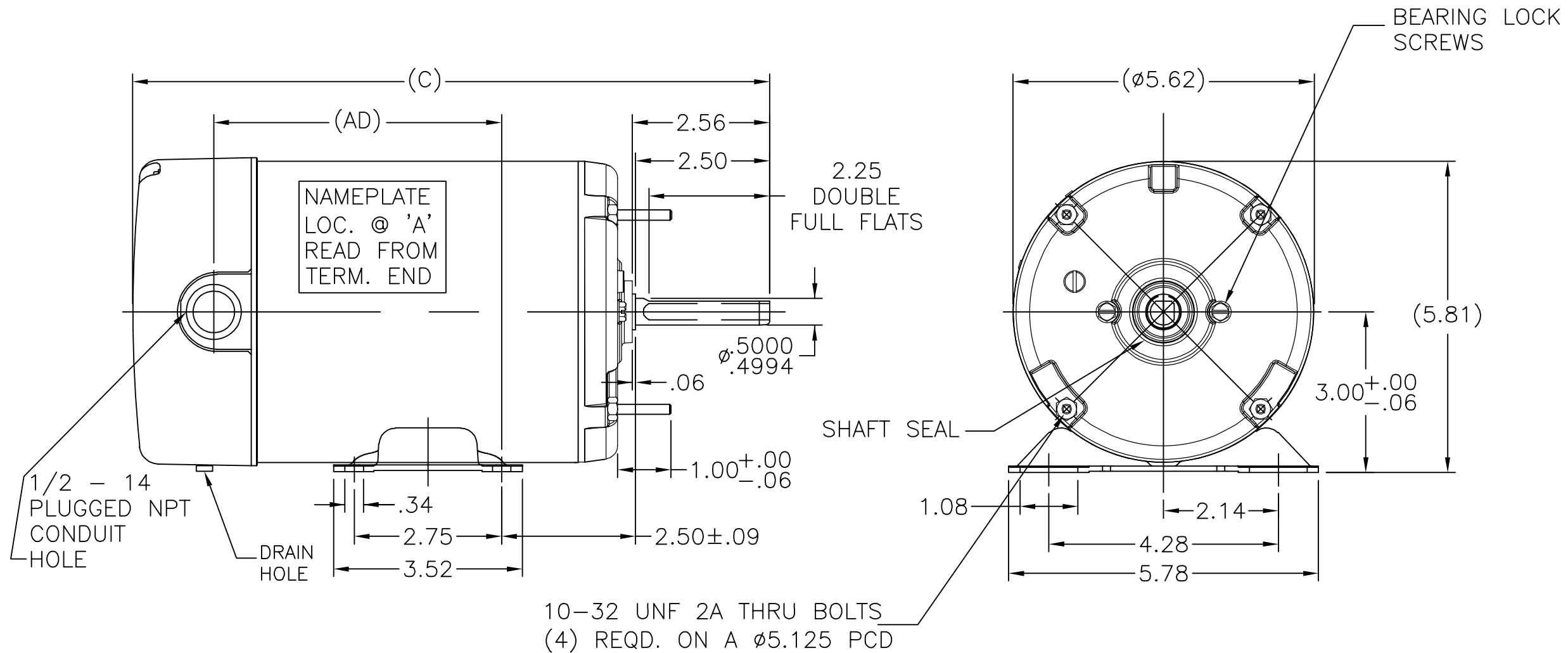

DASH NO.	"C"	"AD"
475	10.64	4.12
500	10.89	4.37
525	11.14	4.62
550	11.39	4.87
600	11.89	5.37

		TOLERANCES UNLESS SPECIFIED		LEESON	ELECTRIC MOTORS GEARMOTORS AND DRIVES	DRAWN KR 02/05/2014
		DEC.	INCHES			CHK VS 02/05/2014
		.X	±.1			APPD
		.XX	±.03			SCALE 1:1
			.XXX	±.005	TITLE OUTLINE - PSC - TENV ENCLOSURE	REF OLPR132173
			.XXX	±.0005	48Z-TWO COMP.-RIGID	FMF A099899.00
A	UPDATED NAMEPLATE LOCATION PER ECO-0062305	PST 12/5/14	PI	.XXXX	MAT'L.	PREV
NO.	REVISION	BY & DATE	CHK	ANG	FINISH	
THIS DRAWING IN DESIGN AND DETAIL IS OUR PROPERTY AND MUST NOT BE USED EXCEPT IN CONNECTION WITH OUR WORK ALL RIGHTS OF DESIGN AND INVENTION ARE RESERVED THIS IS AN ELECTRONICALLY GENERATED DOCUMENT - DO NOT SCALE THIS PRINT			RFP	CAD FILE SS404060	SIZE	DRAWING NO. PAGE OF REV.
			DIST WP		A	SS404060 A

VIEW FROM OUTSIDE OF MOTOR AT SWITCH END.

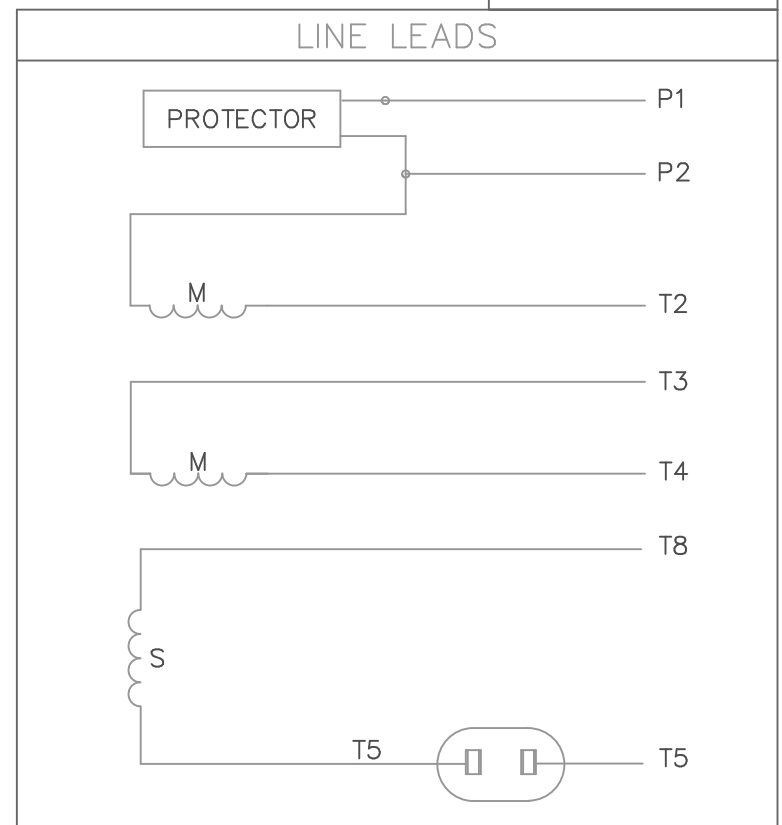
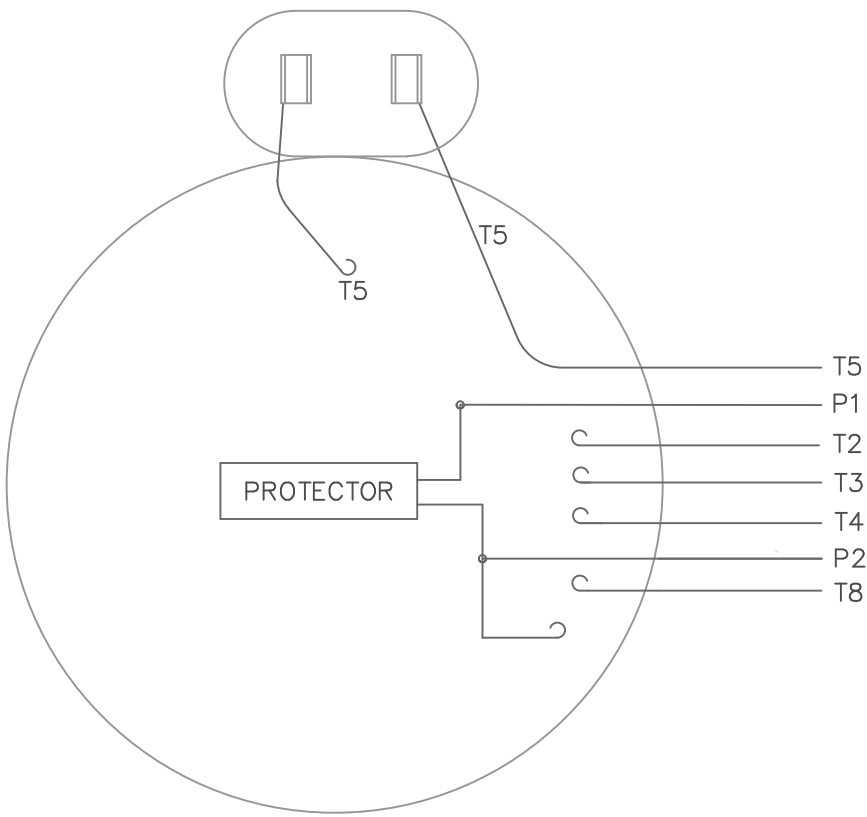

	ROTATION FACING LEAD END	L1	L2	JOIN	INSULATE SEPARATELY
HIGH VOLT	C.C.W.	P1	T4 T5	T2, T3 T8	P2
	C.W.	P1	T4 T8	T2, T3 T5	P2
LOW VOLT	C.C.W.	P1	T2, T4 T5	P2, T3 T8	--
	C.W.	P1	T2, T4 T8	P2, T3 T5	--

		TOLERANCES UNLESS SPECIFIED		 ELECTRIC MOTORS GEARMOTORS AND DRIVES		DRAWN PG 3/4/02	
		DEC.	INCHES			CHK	
		.X	±.1			APPD	
		.XX	±.01			SCALE 1=1	
		.XXX	±.005			REF 005109-01	
		.XXXX	±.0005	MAT'L. DECAL - 004011		FMF 102675	
NO.	REVISION	BY & DATE	CHK	ANG ±1/2'	FINISH	PREV	
THIS DRAWING IN DESIGN AND DETAIL IS OUR PROPERTY AND MUST NOT BE USED EXCEPT IN CONNECTION WITH OUR WORK ALL RIGHTS OF DESIGN AND INVENTION ARE RESERVED THIS IS AN ELECTRONICALLY GENERATED DOCUMENT - DO NOT SCALE THIS PRINT			RFP	CAD FILE	00510915	SIZE	DRAWING NO.
			DIST			A	005109-15
							REV.



1051 CHEYENNE AVE.
GRAFTON, WI 53024
PH. 262-377-8810

CERTIFICATION DATA SHEET

CONN. DIAGRAM: A-005109-15
OUTLINE: A-SS404060-550
WINDING #: PE484278 R2 3

CATALOG #: A099901.00
MOUNTING: F1 ONLY

TYPICAL MOTOR PERFORMANCE DATA

HP	kW	SYNC. RPM	F.L. RPM	FRAME	ENCLOSURE	KVA CODE	DESIGN
1/2	0.37	1800	1625	48Z	TEAO	B	N

PH	Hz	VOLTS	AMPS	START TYPE	DUTY	INSL	S.F.	AMB°C
1	60	115/230	5.2/2.6	ACROSS THE LINE	CONTINUOUS	F3	1.0	40

FULL LOAD EFF:	72	3/4 LOAD EFF:	70	1/2 LOAD EFF:	62	GTD. EFF		ELEC. TYPE	
FULL LOAD PF:	98	3/4 LOAD PF:	96.1	1/2 LOAD PF:	93.2	66		PSC 1 SPEED	

F.L. TORQUE	LOCKED ROTOR AMPS	L.R. TORQUE	B.D. TORQUE	F.L. RISE°C
25.86 OZ-FT	15 / 7.5	16.2 OZ-FT 63 %	46.1 OZ-FT 178 %	0

SOUND PRESSURE @ 3 FT.	SOUND POWER	ROTOR WK^2	MAX. WK^2	SAFE STALL TIME	STARTS / HOUR	APPROX. MOTOR WGT
0 dBA	10 dBA	0 LB-FT^2	0 LB-FT^2	0 SEC.	0	20 LBS.

*** SUPPLEMENTAL INFORMATION ***

DE BRACKET TYPE	ODE BRACKET TYPE	MOUNT TYPE	ORIENTATION	SEVERE DUTY	HAZARDOUS LOCATION	DRIP COVER	SCREENS	PAINT
STANDARD	STANDARD	RIGID-EXTENDED STUDS	HORIZONTAL	FALSE	NONE	FALSE	NONE	GRAY (POWDER)

BEARINGS		GREASE	SHAFT TYPE	SPECIAL DE	SPECIAL ODE	SHAFT MATERIAL	FRAME MATERIAL
DE	ODE						
BALL	BALL	PG-44A	SGL SPL EXT	0.500 x 2.50 IN SEF WITH 2.25 IN DOUBLE FULL FLAT	NONE	1144 STRESSPROOF (C-223)	ROLLED STEEL
6203	6203						

THERMO-PROTECTORS				THERMISTORS	CONTROL	SPACE HEATERS
THERMOSTATS	PROTECTORS	WDG RTDs	BRG RTDs			
NONE	AUT LCK RTR ONLY	NONE	NONE	NONE	FALSE	NONE VOLTS

INVERTER TORQUE: NONE INV. HP SPEED RANGE: NONE
ENCODER: NONE NONE NONE NONE NONE PPR
BRAKE: NONE NONE NONE P/N NONE NONE NONE NONE FT-LB NONE V NONE Hz

*
N
O
T
E
S
*



LEESON ELECTRIC CORPORATION
 TYPICAL PERFORMANCE CURVE for AC MOTOR

Model No A099901.00

Curve at 230 Volts HP 0.50 PHASE 1
60 HZ
0.5 HP VOLTS 115/230

Catalog No A099901.00

HZ 60 RPM 1625

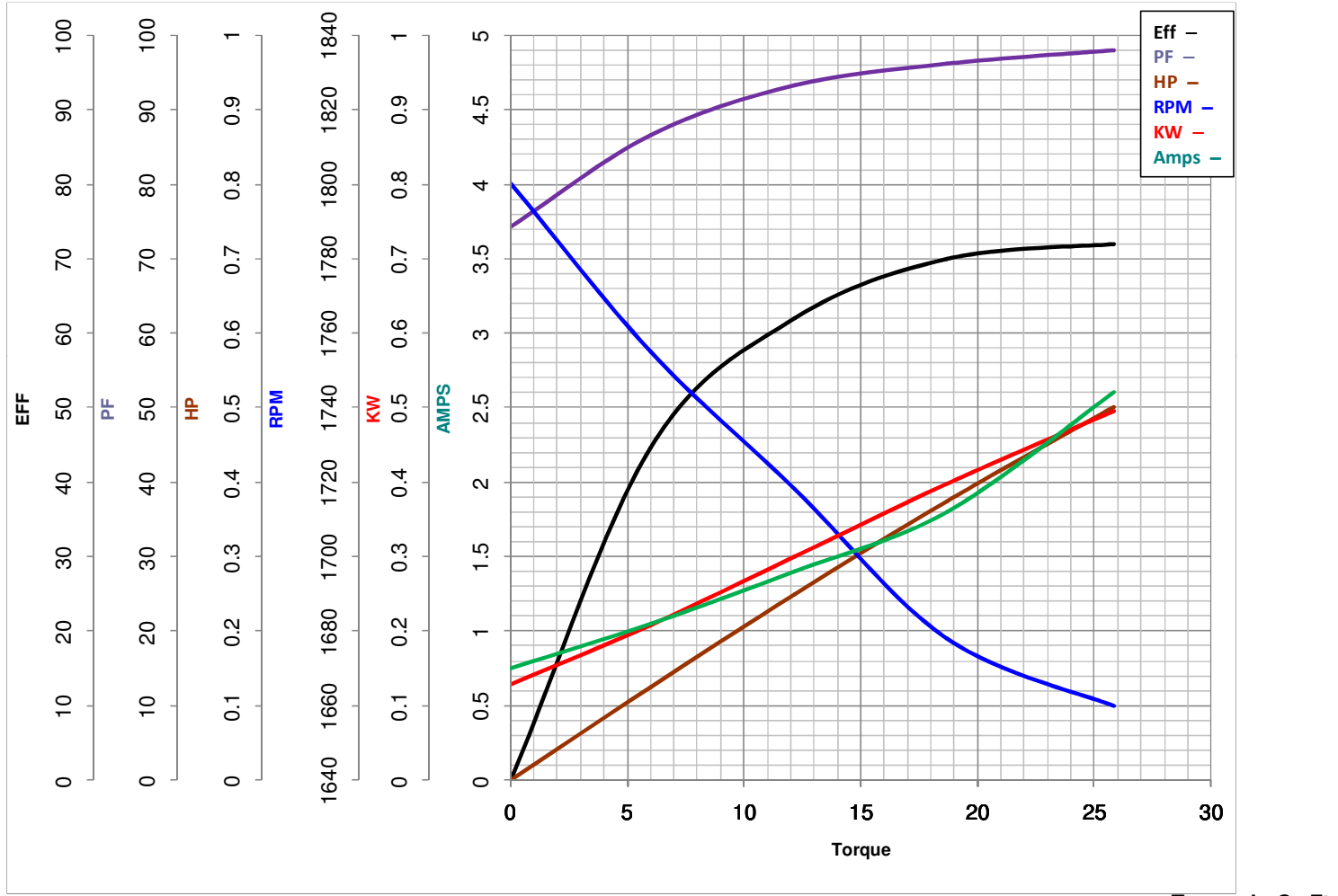

Torque in Oz.Ft

FL TORQUE 25.86 Oz.Ft
 BD TORQUE 46.1 Oz.Ft
 LR TORQUE 16.2 Oz.Ft

FL AMPS 5.2/2.6
 PU TORQUE 16.4 Oz.Ft
 LR AMPS 7.5

WINDING PE484278-3

Date 4/12/2018