

NEMA

Model **SSBN.334F-C**
MFG PN: TSSN56C1/3U4B

Model **SSBN.334F-C**

Product Data Package



MODEL	HP	RPM	VOLTAGE	PHASE	Hz	FRAME	MOUNT	ENCLOSURE
SSBN.334F-C	0.33	1760	575	3	60	56C	Rigid/C-Flange	TENV

Toronto

TOLL FREE 1.888.286.1820
PHONE 905.829.1001
EMAIL info@techttopcanada.com

Montreal

TOLL FREE 1.844.354.5111
PHONE 514.354.1002
EMAIL infoQC@techttopcanada.com

Moncton

PHONE 506.386.5794
EMAIL infoNB@techttopcanada.com

Winnipeg

PHONE 204.633.2779
EMAIL infoMB@techttopcanada.com

Vancouver

PHONE 604.525.1551
EMAIL infoBC@techttopcanada.com



Index

Motor General Data Sheet	P 2
Nameplate Information	P 3
Technical Performance Data	P 4
Motor General Wiring Diagram	P 5
Motor General Outline Drawing	P 6



Model SSBN.334F-C
MFG PN: TSSN56C1/3U4B

ELECTRICAL DATA		
Rated Motor Output Power	0.33	HP
	0.25	kW
Rated Motor Speed	1760	r/min 60Hz
	-	r/min 50Hz
Rated Motor Voltage (+/-10%)	575	V/60Hz
	-	V/50Hz
Rated Motor Current	0.49	A (I _n) @ 60Hz
	-	A (I _n) @ 50Hz
Phase	3	∅
Locked Rotor Current @ High Voltage	-	A (I _n) @ 60Hz
FI Current @ 208V	-	A (I _n) @ 60Hz
Service Factor	1.25	@ 60Hz
	-	@ 50Hz
KVA Code	N	60Hz
	-	50Hz
Nominal Efficiency	79.5	% @ 60Hz
Nominal Power Factor	0.64	cosΦ @ 60Hz
Leads (Qty, Size)	3	18
Connection	Y	-
Coil Resistance	-	Ω
Start Capacitor	-	μF/V
Run Capacitor	-	μF/V
VFD DUTY (S.F. 1.0)		
	RATIO	Hz
Variable Torque	30:1	2 - 60
Constant Torque	15:1	4 - 60
FULL LOAD TEMPERATURE RISE		
Full Load Temperature Rise	39.4	°C @ 60Hz
	-	°C @ 50Hz

GENERAL DATA		
Frame Size	56C	
Enclosure	TENV	
Mounting	Rigid/C-Flange	
Approximate Weight (lbs.)	34.1 lbs.	
Casing Material / Fan Cover	Stainless Steel	Stainless Steel
Shaft Material	304 SS	
NEMA Design	B	
Degree of Protection (IP)	69K	
Insulation Class / Temp Rise (60Hz)	F	B
Tropicalization	YES	
Duty	Cont. / S1	
Conduit Box Location	F1	
Feet Removable / Double Drilled	NO	NO
Paintwork	unpainted	
	unpainted	
MECHANICAL DATA		
Bearing DE Side	6205 ZZ	
Bearing ODE Side	6204 ZZ	
Grease Type	Food grade Mobilgrease™ FM 222	
Compensation Ring (wavy washer)	NDE	
Moment of Inertia (lb-ft ²)	-	
Sound Pressure @ 3 FT dBA	-	
SITE CONDITIONS		
Ambient Temperature (°C)	40	
Meters Above Sea Level (MASL)	1000	
HAZARDOUS LOCATIONS		
CSA Certified	A, B, C & D	
Temperature Code	-	-

Questions? Call 1.888.286.1820

NEMA

Model SSBN.334F-C
MFG PN: TSSN56C1/3U4B

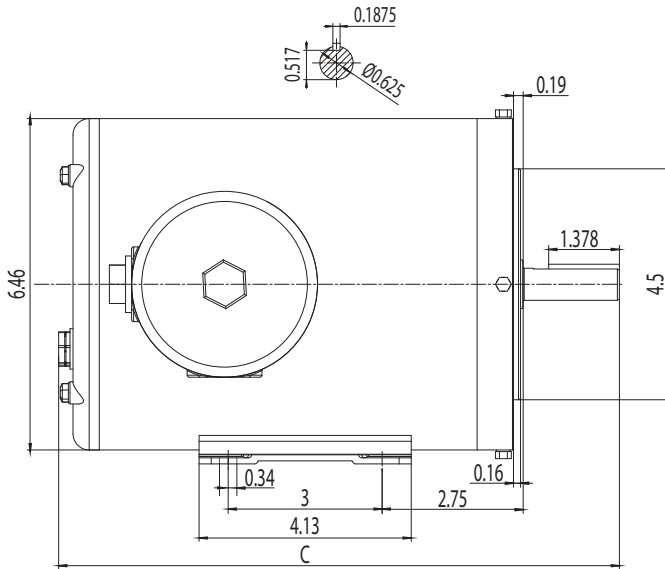

HP	°C
0.5 2P	10.4
0.33 4P	10.4
0.5 4P	11
0.75 2P	11
0.75 4P	11.6

NAMEPLATE DATA	60Hz	50Hz
Horse Power	0.33	-
RPM	1760	-
Voltage	575	-
Full Load Amps	0.49	-
Service Factor	1.25	-
KVA Code	N	-
Full Load Amps (208V)	-	-
Nominal Efficiency	79.5	-
Nominal Power Factor	0.64	-
Design	B	
Frame	56C	
Enclosure Type	TENV	
IP Rating	69K	
Duty	Cont. / S1	
Insulation Class	F	
Ambient Rating	40	
Drive End Bearing	6205 ZZ	
Opposite Drive End Bearing	6204 ZZ	
Weight (lbs)	34.1	

NAMEPLATE LAYOUT

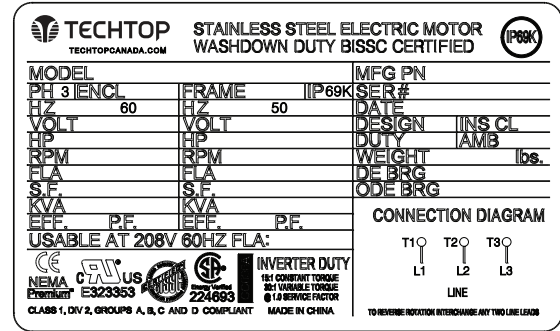

VFD DUTY (S.F. 1.0)	RATIO	Hz*
Variable Torque	30:1	2 - 60
Constant Torque	15:1	4 - 60

*For max speed please contact Techtop Canada

HAZARDOUS LOCATIONS	CSA COMPLIANT
Class / Division	Class 1, Div. 2
Groups	A, B, C & D

Questions? Call 1.888.286.1820



Model SSBN.334F-C
MFG PN: TSSN56C1/3U4B

Torque Speed (T-n) Curve

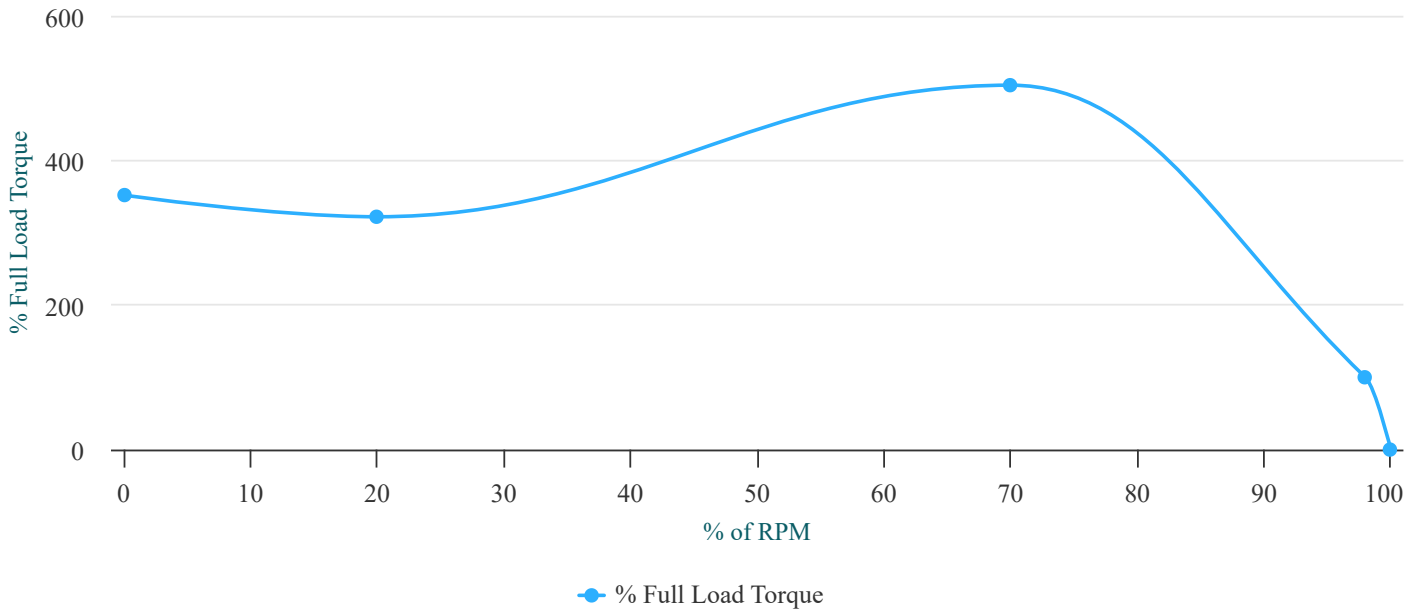

PERFORMANCE LOAD VALUES, HIGH VOLTAGE, 60Hz

TYPICAL PERFORMANCE - NOT GUARANTEED VALUES

TORQUE VALUES	TORQUE (lb-ft)	TORQUE (% FULL LOAD)	PERFORMANCE VALUES	
Locked Rotor Torque	3.5	352	Start Configuration	DOL
Pull-Up Torque	3.2	322	Starting Current (A)	-
Breakdown Torque	5	504	No-Load Current (A)	0.4
Full Load Torque	1	100	No-Load Power Factor	-

% OF RATED LOAD	25	50	75	100	125	S.F. 1.25
Line Amperes (A)	0.4	0.4	0.4	0.5	0.5	0.5
Efficiency (%)	56.6	71	76.9	79.7	81	81
Speed (r/min)	1778	1771	1764	1756	1748	1748
Power Factor (cosΦ)	0.28	0.43	0.55	0.64	0.71	0.71
Input Power (kW)	0.11	0.18	0.24	0.31	0.39	0.39

Questions? Call 1.888.286.1820

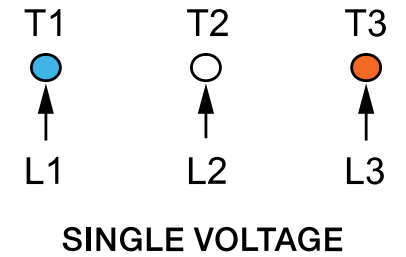
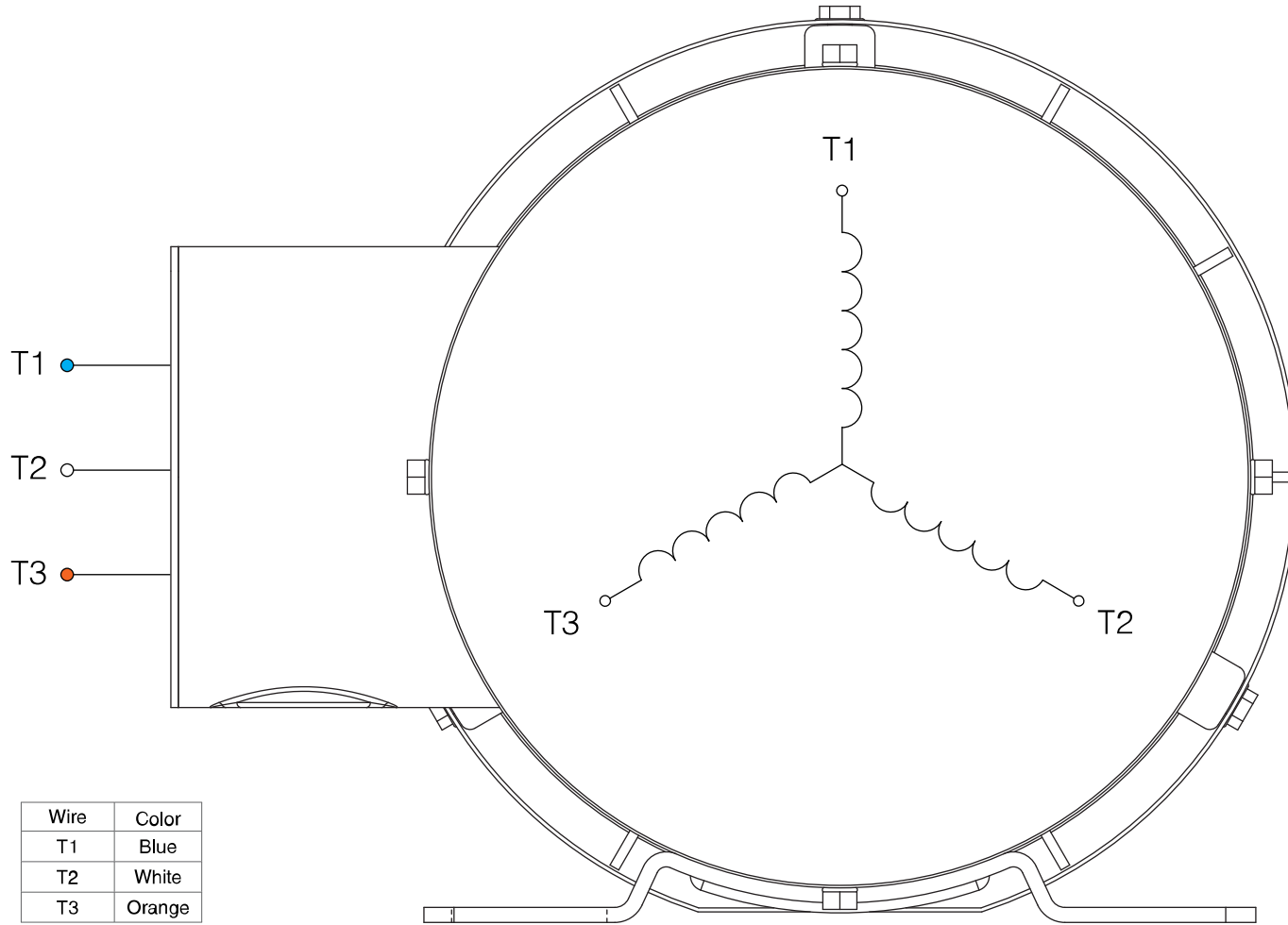

NOTES:

1. CCW ROTATION FACING ODE FOR CONNECTIONS SHOWN
2. TO REVERSE ROTATION, SWAP ANY TWO INPUT LINES
3. WHEN MOTOR IS IN F1 POSITION, LEADS INDICATED WITH "*" EXIT THE CASING ABOVE THE CENTER LINE OF THE MOTOR, THE REMAINING LEADS EXIT BELOW THE CENTER LINE
4. LEADS MUST BE NUMBERED AND COLORED AS SHOWN
5. DIAGRAMS FOR REFERENCE ONLY



NEMA 3Ø Y 3-Lead Single Voltage

DRAWING NUMBER:

NEMA-3-3-Y-SS

CONNECTION:

Y

NUMBER OF LEADS:

3

THERMAL PROTECTION:

-

ISSUED DATE

24/02/25

STAINLESS STEEL IP69K MOTORS

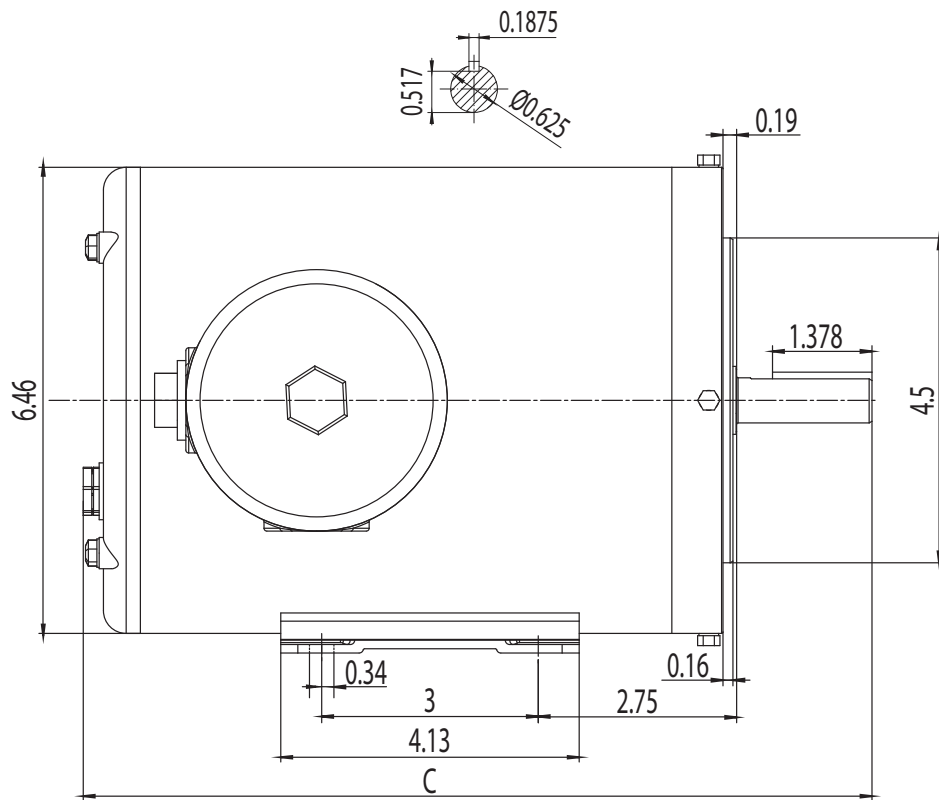

HP	"C"
0.5 2P	10.4
0.33 4P	10.4
0.5 4P	11
0.75 2P	11
0.75 4P	11.6

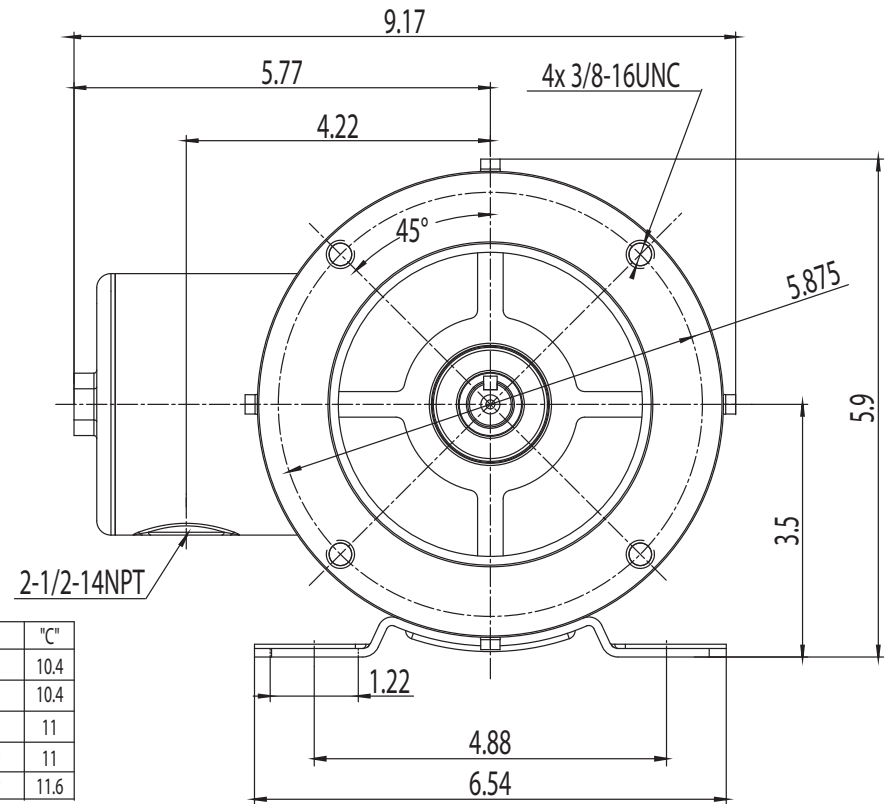

NEMA Premium TENV 56C

DRAWING NUMBER:

SS3-NV-56C

DIMENSIONS:

Inches

MOUNTING:

Rigid/C-Flange

CASING MATERIAL:

Stainless Steel

ISSUED DATE

24/02/25

STAINLESS STEEL IP69K MOTORS